

NOTES:

1. UPPER SASH TO BE REMOVED FOR MODIFICATION. UPPER SASH TO BE INOPERABLE AFTER MODIFICATION AND REINSTALLATION.
2. ALL FRAMING TO BE 1-3/4" THICK PINE CONSTRUCTION TO MATCH SASH. ALL JOINERY TO BE MORTISE AND TENON. NAILS TO BE USED IN CONSTRUCTION WITH JOINERY.
3. SIDE FILLER PANELS AND BOTTOM PANEL TO BE 3/4" THICK PLYWOOD AND / OR GLASS CONSTRUCTION.
4. WOOD FRAMING AND PLYWOOD FILLER PANELS TO BE PRIMED AND PAINTED STONE GRAY.
5. ALL GLASS TO BE 1/4" LAMINATED GLASS WITH WOOD STOPS.
6. WINDOW A/C UNIT TO BE SECURED IN SASH OPENING BY SCREWING ANGLE FLANGES IN TO A/C UNIT CASING AND WOOD FRAMING.
7. SEAL ALL CRACKS WITH WHITE LATEX CAULK.

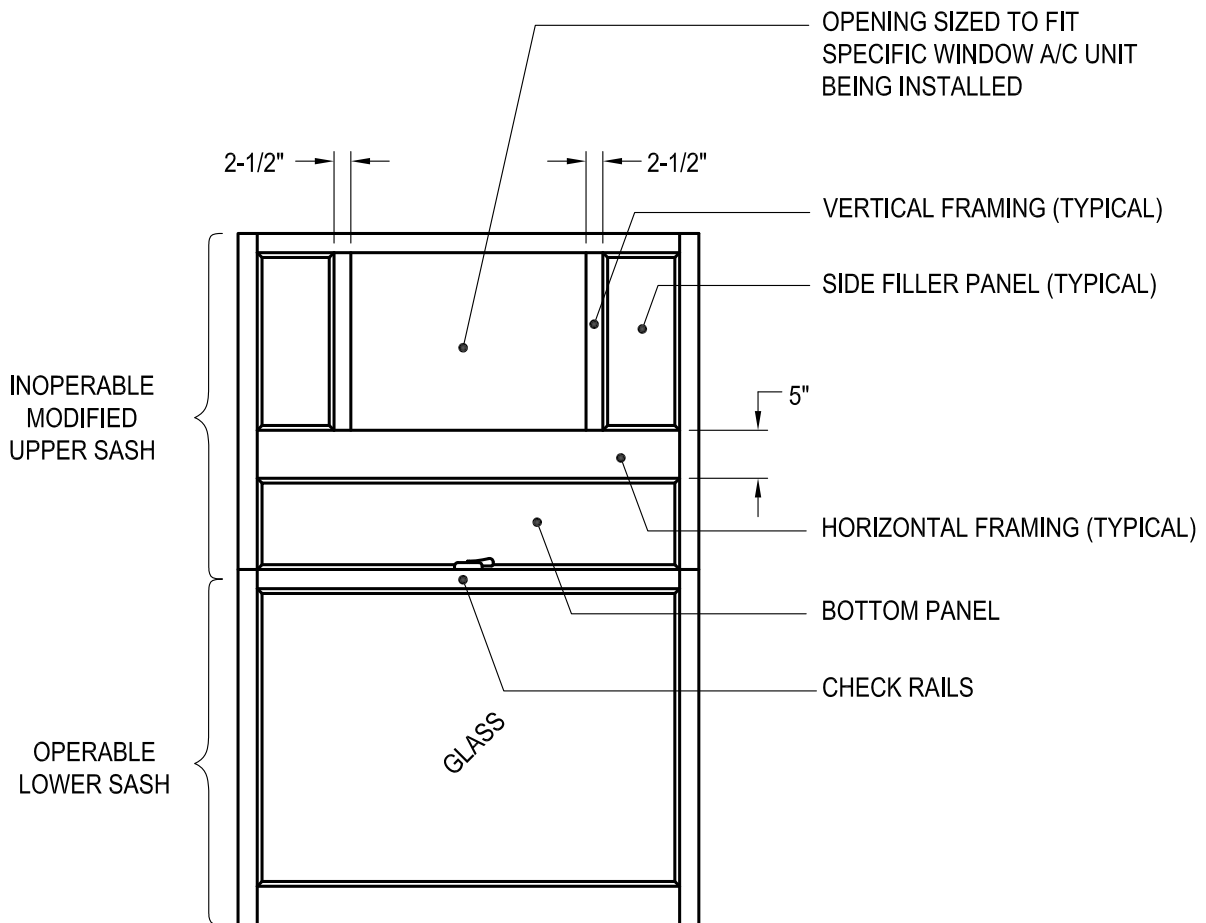

NOTE: WINDOW FRAME *NOT SHOWN*.



WINDOW A/C UNIT INSTALLATION IN UPPER SASH

NOT TO SCALE

23 81 16-2

WINDOW A/C UNIT INSTALLATION IN UPPER SASH

Date: June 15, 2013

Dwg. No.: 23 81 16-2